

Sudenga

INDUSTRIES, INC. SINCE 1888

Hi-Efficiency Portable Augers

- 8", 10", and 12" Auger Diameters
- 57 through 82 ft. Lengths
- Painted or Galvanized Tubes*

12" Augers now
available in 92 - 122 ft.
lengths.

MADE IN
USA

Auger Capacities

| | |
|----------|-------------|
| 8" Dia. | to 3200 BPH |
| 10" Dia. | to 5000 BPH |
| 12" Dia. | to 7000 BPH |

Hydraulic scissors
transport is standard.

*12" augers are painted only.

Swing-around Hopper available
with hydraulic positioning.

Hi-Efficiency Portable Augers

SPECIFICATIONS

| | 8" | 10" | 12" |
|--------------|---|-------------------------|---------------|
| Tube Lengths | 57', 61', 65', 71' | 61', 66', 71', 76', 82' | 61', 72', 82' |
| Tube Gauge | 14 | 12 | 12 |
| Tube Finish | painted or galvanized | | painted |
| Flighting | 3/16" | 3/16" | 1/4" |
| Driveline | Direct constant velocity joint on PTO-to-flighting connection; double bearings; shear pin protection. | | |
| Transport | Hydraulic scissors lift; reinforced arms on 12", 4-bolt rims (8" augers) or 6-bolt rims (10"/12" augers), roller bearings for road transport. Transport widths - 10 ft. (8" augers) and 10.5 ft. (10"/12" augers). | | |
| Swing Hopper | Mechanically driven by roller chain & double gearbox from auger flight, gimbal mount is easy to position, UHMW sealed hopper joint* keeps weather out and grain in. 10" and 12" hoppers are hinged at the hopper-to-incline joint. CV joint is standard on 10" and 12". Hopper intake flighting is 5/16" thick on all models. | | |

REACH & ELEVATION

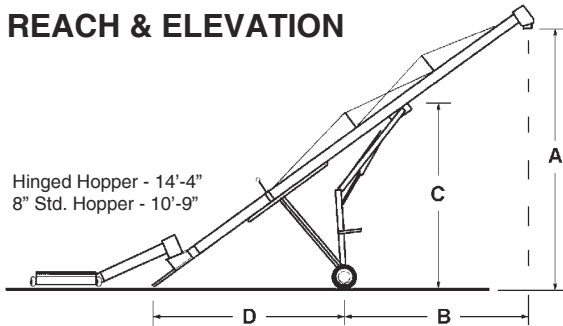

| Augers at 40° | 57' | 61' | 65' | 71' | 76' | 82' |
|---------------|-----|-----|-----|-----|-----|-----|
| A - Elevation | 39' | 42' | 46' | 49' | 52' | 56' |
| B - Reach | 21' | 25' | 25' | 29' | 33' | 33' |
| C - Height | 20' | 20' | 25' | 25' | 25' | 28' |
| D - Distance | 21' | 21' | 25' | 25' | 25' | 28' |

| Augers at 30° | 57' | 61' | 65' | 71' | 76' | 82' |
|---------------|-----|-----|-----|-----|-----|-----|
| A - Elevation | 30' | 33' | 36' | 39' | 42' | 44' |
| B - Reach | 23' | 28' | 28' | 33' | 37' | 37' |
| C - Height | 15' | 15' | 25' | 15' | 19' | 21' |
| D - Distance | 23' | 23' | 25' | 23' | 29' | 34' |

Gimbal mount Mechanical Hopper

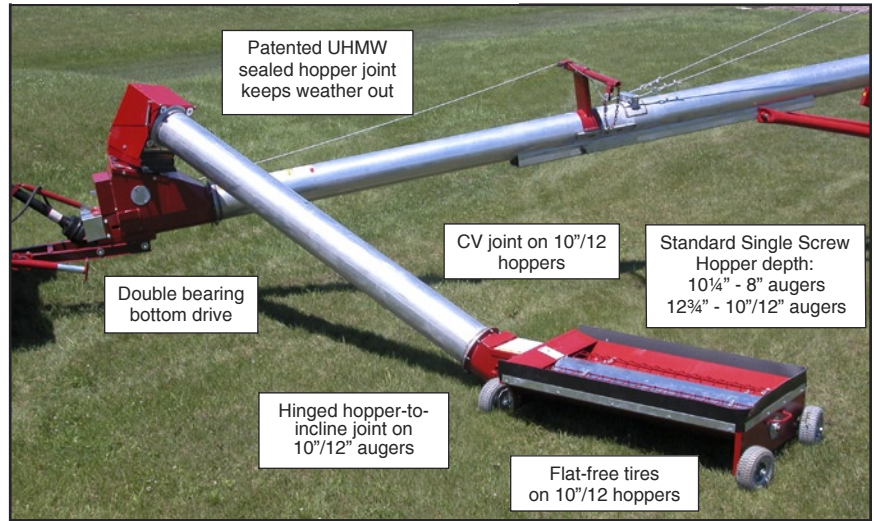

Twin Screw Hopper

Standard on 12" augers. Optional on 10".



9½" overall hopper height - the lowest twin screw hopper in the industry! Left and righthand hopper flights for maximum capacity and even feeding.

OPTIONS & ACCESSORIES

- 1/4" ga. flight - for 8" & 10" augers.
- Discharge Spout - for 8" & 10" augers.
- Overflow Spout - for 8" & 10" augers (std. on 12").
- Bucket Spout, 4 & 6 ft. lengths - for 8"/10" augers.
- Metallflex Hose, 3 ft. length - for 8" & 10" augers.
- Screen Tube, 4 ft. of screen on incline tube, includes cover - for 8" & 10" augers.
- Low Profile Twin Screw Hopper - for 10" augers (std. on 12").
- Hydraulic Power Rotate Kit for Hopper - for 10" & 12" augers. Hydraulic positioning for Hopper.
- Side Drive Kit - Positions tractor at 90° to auger for more hopper swing latitude.

Incline tube head opens fully for easy maintenance.



Easy access to grease fittings.



Distributed By:

SUDENGA INDUSTRIES, INC.

Box 8 • 2002 Kingbird Ave. • George, IA 51237 USA
 1-888-SUDENGA (783-3642) • 1-712-475-3301 • Fax: 1-712-475-3320
 sales@sudenga.com • www.sudenga.com